

VERONA LS

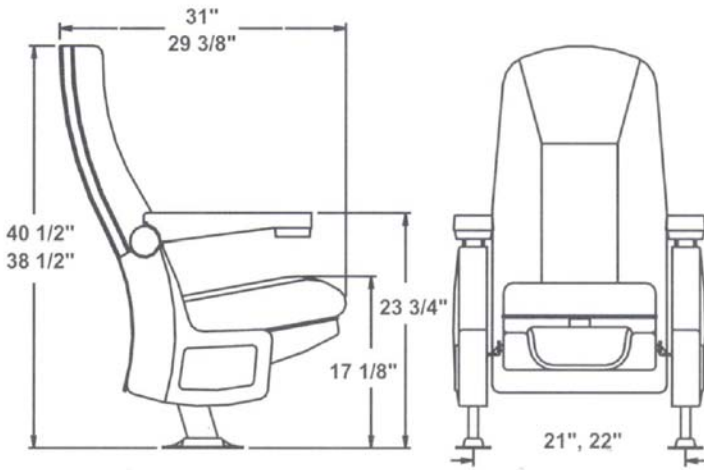

Specifications

Cushions - Cold molded polyurethane foam with ergonomic design.

Back - Impact resistant textured linear polypropylene, injection molded with structural ribs for strength and ergonomic curves for natural body support

Frame Structure - Stress tested rectangular steel tube in various gauges.

Paint - Electrostatic powder paint, oven baked at 200° C.

Fabric - 100% Marquesa Lana (polyolefin) with fire retardant. Meets California Technical Bulletin 117, Section ECS-191-53

High quality plastics are durable and easy to clean.

Seats use a gravity lift mechanism. There are no springs to ever squeak or break.